

TITAN HEAVY DUTY EXTERNAL REAR CAMERA

TITAN EXP IP69



FEATURES

- 1.3 MEGA PIXEL SONY CMOS SENSOR
- 2.9mm(120°)
- Resolution: 720p
- Waterproof (Certify IP 69K)
- 5M & 15M Extension Cable Options

DIMENSION

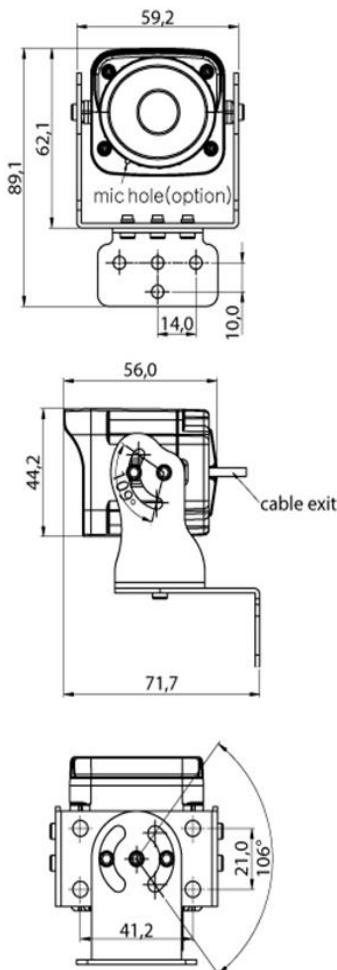

SPECIFICATION

Model	TITAN-EXP-IP69
Image Device	1.3 Mega-Pixel Sony CMOS Sensor
Video Output	AHD 1.0 (720P@30 / 25fps)
Effective Pixels	1305(H) x 977(V)
TV System	NTSC / PAL
WDR/BLC	OFF / WDR / BLC
Synchronization	Internal
Sensitivity	0 lux [IR LED ON]
Lens	f=2.9mm lens (120°)
IR-LED	8 pcs
Power Source	DC 5V
Operating Temperature	-20°C~+85°C (Humidity : 10%~85% RH)
IP Class	IP 69K

TITAN INTERNAL IR CAMERA

TITAN INTERNAL IR



FEATURES

- 1.3 MEGA PIXEL SONY CMOS SENSOR
- 2.9mm LENS (120°)
- Resolution : 720P
- WDR (Wide Dynamic Range)
- 1M & 5M Cable Options

DIMENSION

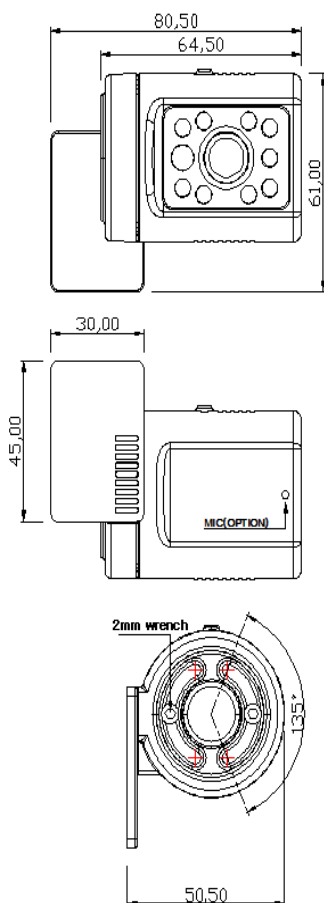

SPECIFICATION

Model	TITAN-INTERNAL-IR
Image Device	1.3 Mega-Pixel Sony CMOS Sensor
Video Output	AHD 1.0 (720P@30 / 25fps)
Effective Pixels	1305(H) x 977(V)
TV System	NTSC / PAL
WDR/BLC	OFF / WDR / BLC
Synchronization	Internal
Sensitivity	0 lux [IR LED ON]
Lens	f=2.9mm lens (120°)
IR-LED	9 pcs
Power Source	DC 5V
Operating Temperature	-20°C~+85°C (Humidity : 10%~85% RH)

TITAN INTERNAL NON-IR CAMERA

TITAN-INTERN



FEATURES

- 1.0 MEGA PIXEL CMOS SENSOR
- Standard optical format of 1/4 inch
- F=2.9mm LENS (105°)
- Resolution : 720P
- 5M Extension Cable